

My Burner Design

By Laurence Kress Hults

Burner orifice setup.

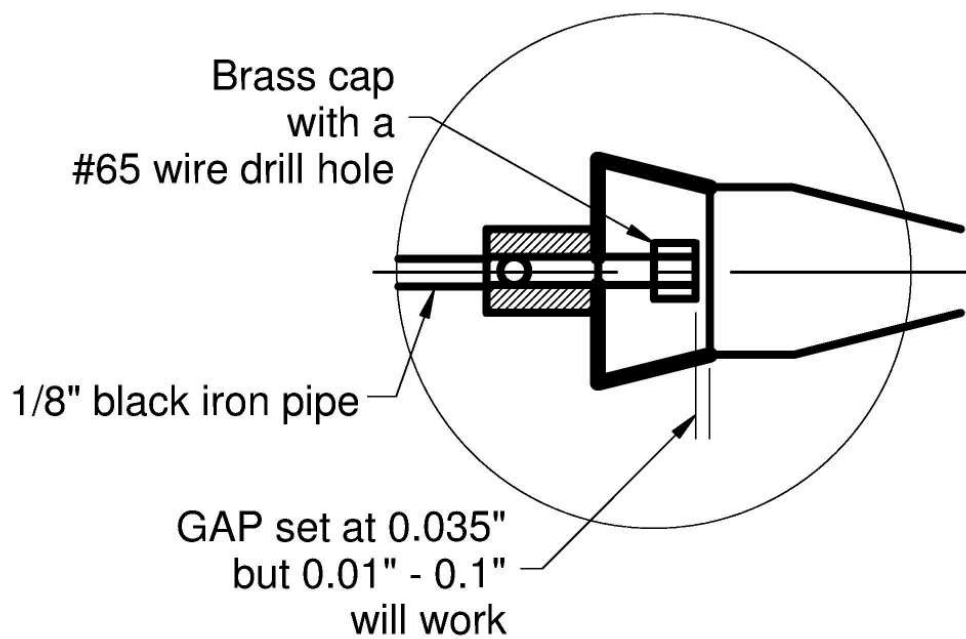

Burner adjustment
in relation with burner tube holder.

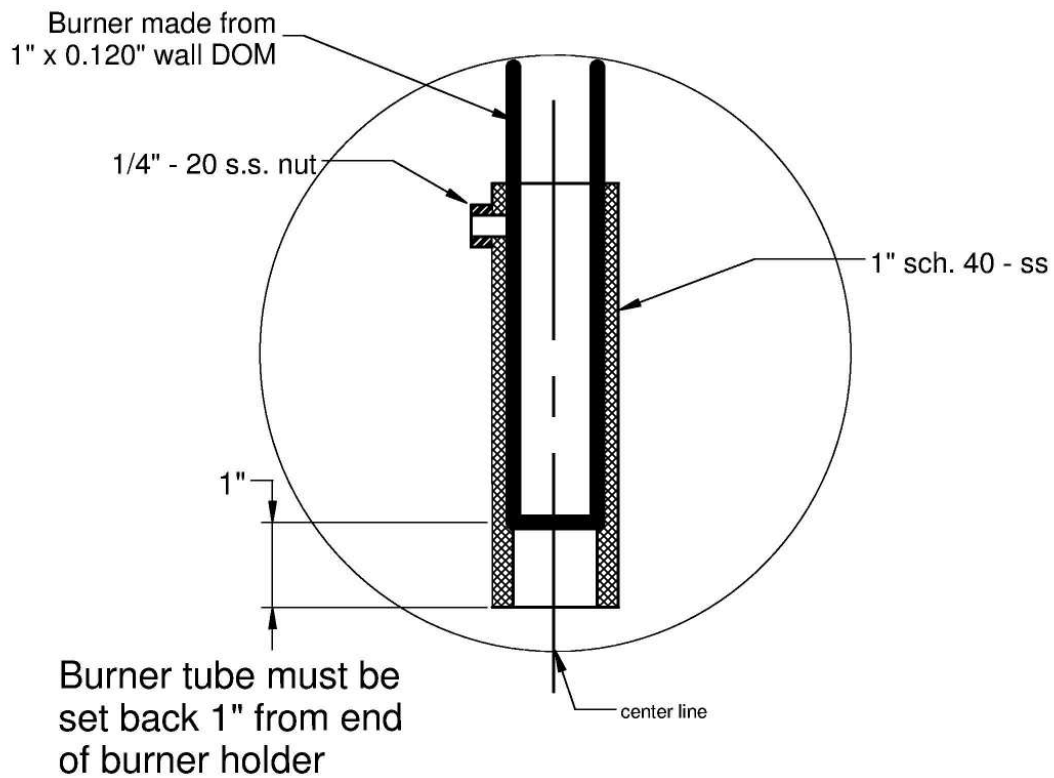

Burner layout
U.S. Patent Pending

